

INSTALLATION INSTRUCTIONS FOR 4.75" (LARGE) RUPTURE DISCS USED WITH SALCO QUICK INSPECTS (STYLE 1)

Inspection of the Quick Inspect Housing:

Note: Only an AAR Class G Registered facility (minimum) can remove or replace a safety vent (QI) housing to a tank car except to replace the rupture disk kind. (MSRP CIII, Appendix B, Section 3.4, Table B4)

1. Inspect for possible defects including cracks, signs of excessive wear, missing components, etc. and replace if necessary.

To inspect the rupture disc and gaskets:

2. Thoroughly inspect both sides of the rupture disc (Figure 1) by either of the below methods. Method A is preferred.
 - a. Remove the entire quick inspect housing to expose the rupture disc. It is also recommend to inspect the gaskets at this time.
 - b. Remove one bolt and loosen the other bolts to allow the disc to slide out from under the housing.
3. Replace disc if it is missing any OEM gaskets, shows any signs of discoloration, if the disc is blown or if there are any other suspect conditions.
4. **DO NOT REMOVE ANY GASKET AFFIXED TO EITHER SIDE OF THE DISC.**
5. Make sure the disc is properly centered beneath the QI housing. It should fit snug within the bolt circle when the fasteners are in place.
6. Inspect the fasteners to ensure they are in good condition, replace if necessary.
7. Re-fasten or re-apply the Quick Inspect.
8. Be sure flange gasket is in place before installation. Use only Salco Gaskets or equivalent. Attach unit to car with (3) 5/8" bolts. Tighten bolts rotationally and incrementally to ensure even pressure. Torque requirements 35-40 Ft. Lbs. **DO NOT OVER TIGHTEN**
9. Replace the rupture disc securement cap. Tighten until it is **HAND SNUG**.
10. Using the SALCO Quick Inspect Wrench (QI261HDL, Figure 2) - lay the wrench across the tabs (Figure 3) and ensure the rupture disc securement cap is tool tight.

DO NOT OVER TIGHTEN! Over tightening of the securement cap may affect performance.

If you do not have a quick inspect wrench, you may place a 3/8" flat bar across the tabs and use a rubber mallet to gently tap the bar to ensure a tool tight condition.
11. Follow your companies leak test procedure.
12. Apply top cap and tighten until **HAND TIGHT**.
13. If desired, apply cable seal for tamper evidence.



Figure 1. 4.75" Rupture Discs - Oseco and Zook



Figure 2.
Quick Inspect Wrench

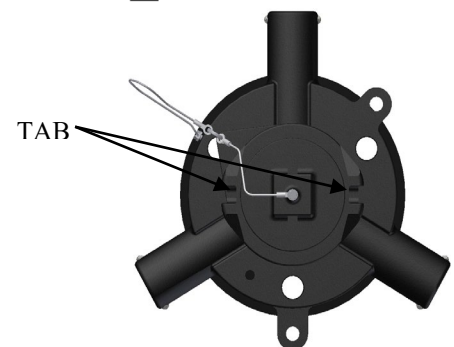

Figure 3.

