

## INSTALLATION INSTRUCTIONS FOR LIFT ASSIST - LAD20TR (TRINITY CAR – 20” Manway Cover)

**GENERAL NOTE: - ALL SHARP EDGES TO BE DEBURRED.**

Upon receiving the lift assist kit (spring, eyebolts, bushings, fasteners) inspect to make sure it has not been damaged in shipment and that all items listed in the drawing BOM are present and accounted for (see drawing LAD20TR).

1. Remove existing hinge pin assembly (see Fig. 1).
2. Apply a small amount of lube (grease, machine oil, etc..) onto 7/8" hex bolt threading. Secure both bushings and the dual torsion spring with a 7/8" hex bolt and a 7/8" top lock nut (see Fig. 2).
3. Position eyebolts and angle brackets as shown in Fig. 3 and weld angle brackets to the cover. Cover should be in a vertical, open position.
4. Secure eyebolts to angle brackets with 3/8" nylon hex lock nuts (see Fig. 3). Make sure to chisel check the eyebolt threading after the nylon hex lock nuts have been applied.

**WARNING:**

**DO NOT CLOSE THE COVER UNTIL ANGLE BRACKETS HAVE BEEN COMPLETELY WELDED TO THE COVER AND EYEBOLTS SECURED TO THE ANGLE BRACKETS.**

**Fig. 1**

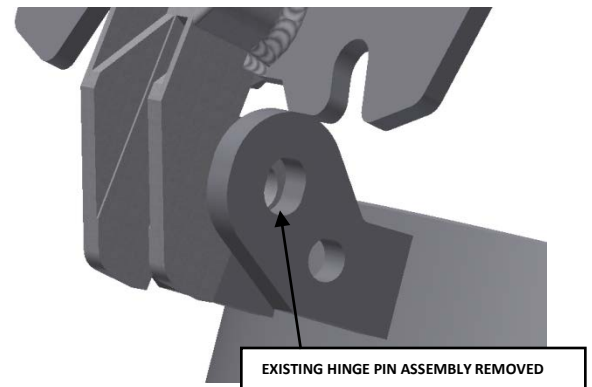

**Fig. 2**

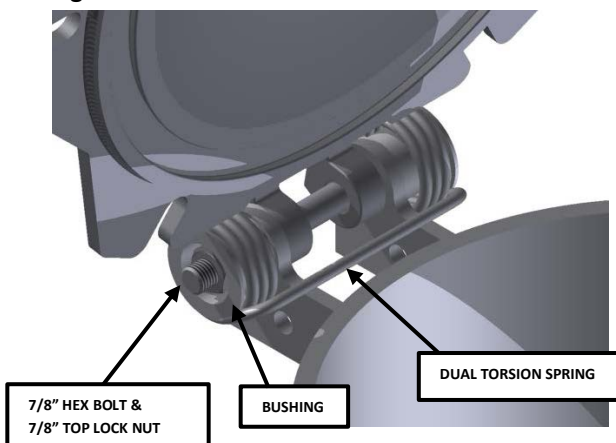

**Fig. 3**

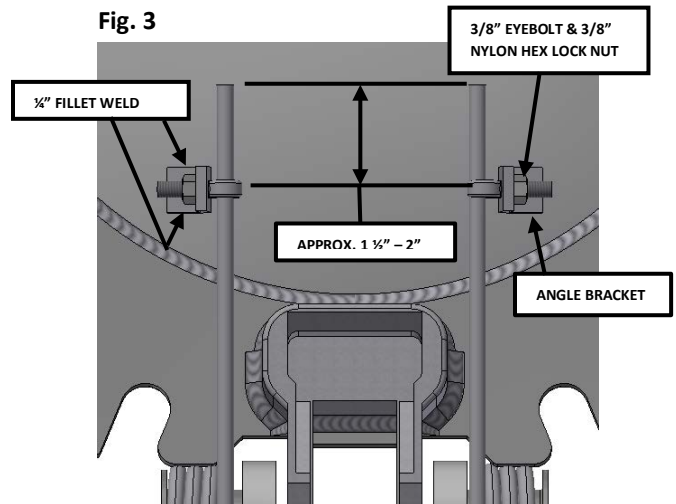

**WARNING: TO DISARM THE LIFT ASSIST SPRING, UNFASTEN AND REMOVE BOTH EYEBOLTS FROM THE MANWAY COVER WHILE KEEPING THE COVER IN VERTICAL, OPEN POSITION.**