

## INSTALLATION INSTRUCTIONS FOR LIFT ASSIST - LAD20ARI03 (ARI CAR – 20” Manway Cover)

**GENERAL NOTE: - ALL SHARP EDGES TO BE DEBURRED.**

Upon receiving the lift assist kit (spring, eyebolts, bushings, fasteners) inspect to make sure it has not been damaged in shipment and that all items listed in the drawing BOM are present and accounted for (see drawing LAD20ARI).

1. Remove existing hinge pin assembly (see Fig. 1).
2. Apply a small amount of lube (grease, machine oil, etc..) onto 7/8" hex bolt threading. Secure both bushings and the dual torsion spring with a 7/8" hex bolt and a 7/8" top lock nut (see Fig. 2).

**NOTE: The 7/8" top lock nut has three indentations on one of its flat sides. The three indentations (see Fig. 5) should always face away from the 7/8" hex bolt.**

**Fig. 1**

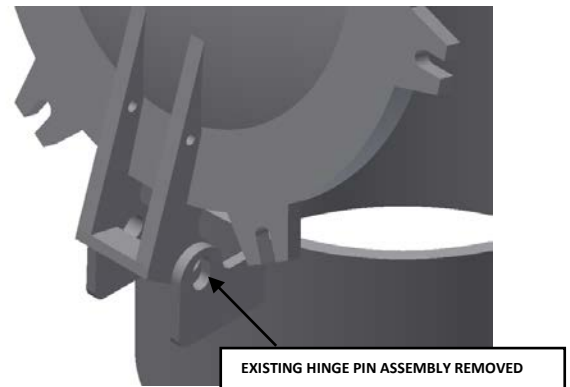

**Fig. 2**

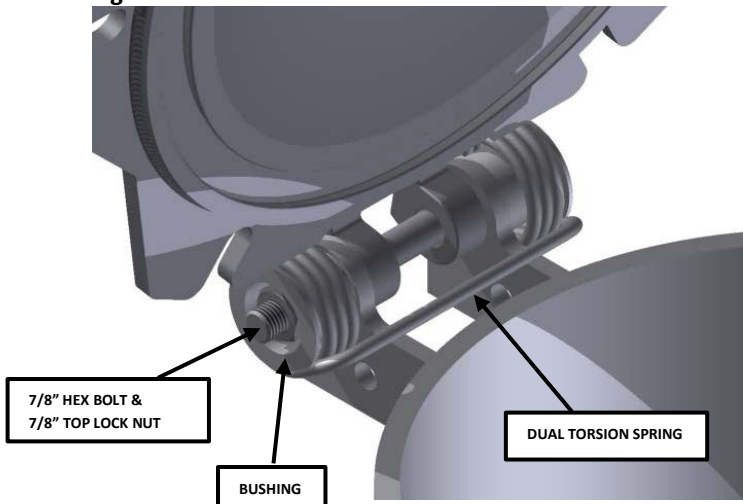

3. Secure dual torsion spring arms to cover using 3/8" eyebolts, 3/8" hex nuts and 3/8" nylon hex lock nuts (see Fig. 3).

**NOTE: Regular 3/8" hex nut is always thread onto the 3/8" eyebolt by hand first. The 3/8" nylon hex lock nut is threaded onto 3/8" eyebolt last (see Fig.4). Make sure to chisel check the eyebolt threading after the nylon hex lock nut has been applied.**

**Fig. 3**

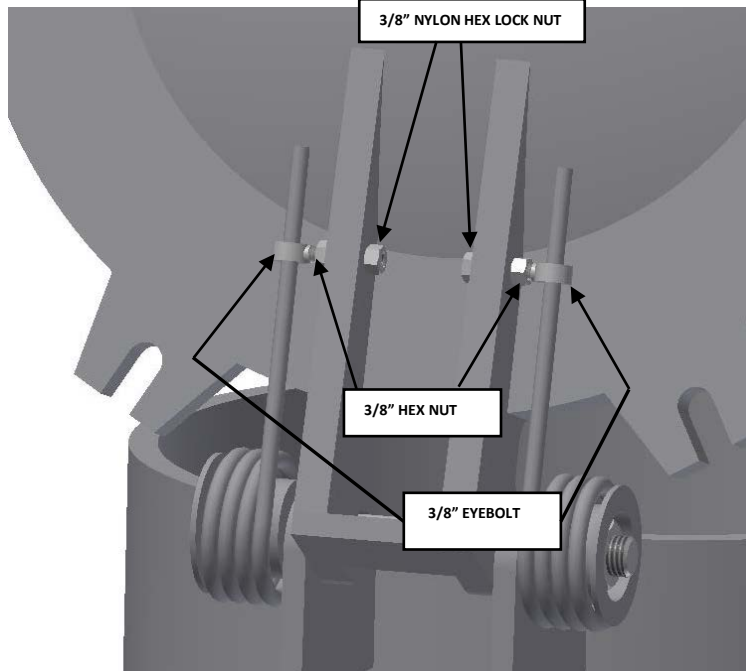

**NOTE:** If the manway cover hinge does not have pre-drilled holes, weld the angle brackets to the cover and secure the 3/8" eyebolts to angle brackets with 3/8" nylon hex lock nuts. See Fig. 4.

**Fig. 4**

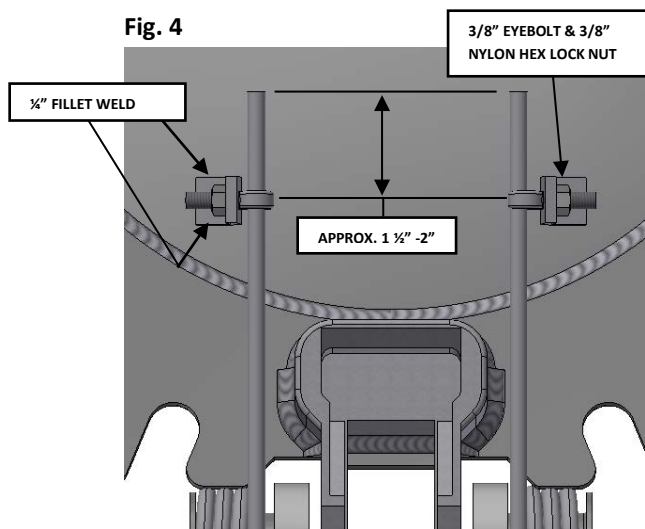

**Fig. 5**

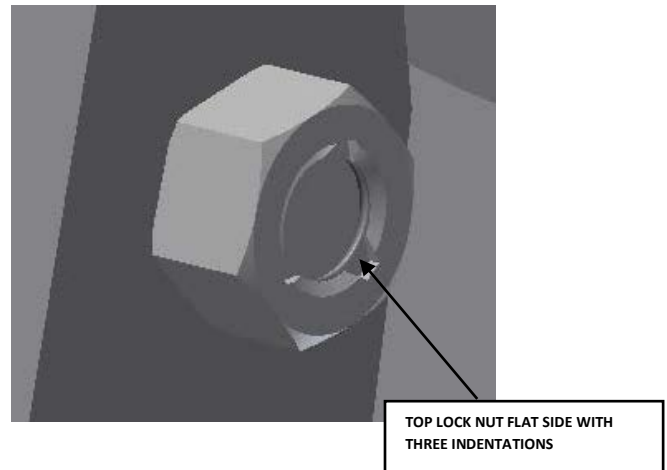

**WARNING: TO DISARM THE LIFT ASSIST SPRING, UNFASTEN AND REMOVE BOTH EYEBOLTS FROM THE MANWAY COVER WHILE KEEPING THE COVER IN VERTICAL, OPEN POSITION.**