



INSTALLATION INSTRUCTIONS FOR LIFT ASSIST – LAD20ARI01S and LAD20ARI01 (8-BOLT ARI MANWAY COVER)

GENERAL NOTE: - ALL SHARP EDGES TO BE DEBURRED.

Upon receiving the lift assist kit (spring, stopper bar, angle brackets, eyebolts, bushing, fasteners) inspect to make sure it has not been damaged in shipment and that all items listed in drawing BOM are present and accounted for (see drawing LAD20ARI01S or LAD20ARI01).

1. Remove existing hinge pin assembly (see Fig. 1).
2. Position and weld the 3/4" round stopper bar to hinge on nozzle as shown in figure2.

Fig. 1

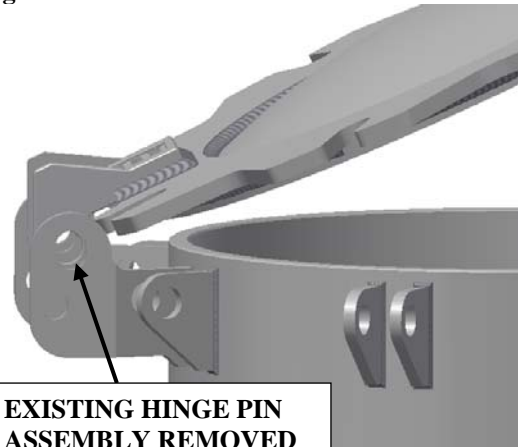
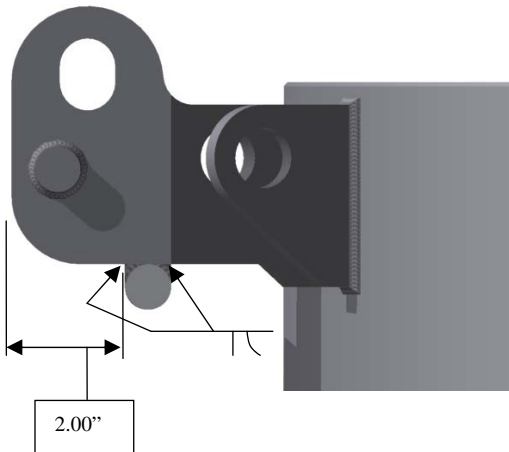
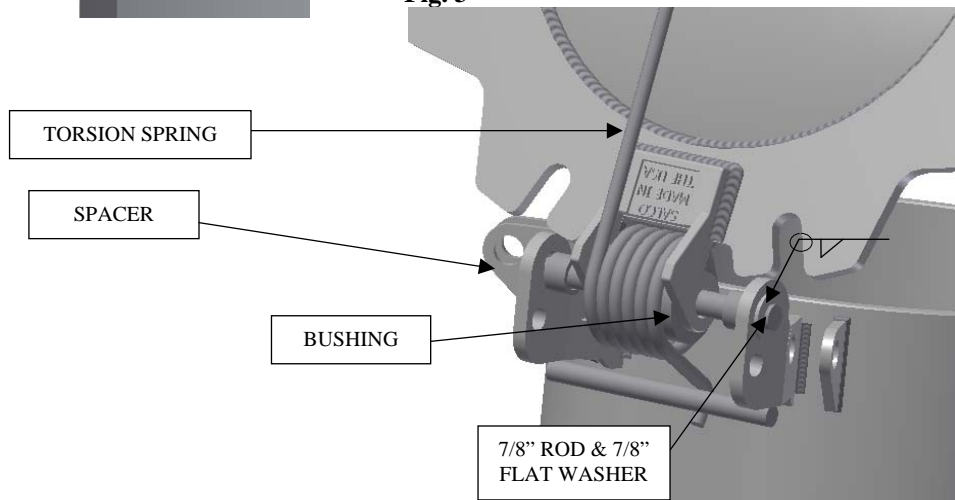

Fig. 2



3. Secure the bushing and the torsion spring with a 7/8" rod, 7/8" flat washers and spacers (see Figure 3).

Fig. 3



1385 101st St., Suite A Lemont, IL 60439
ph (630) 783-2570 Fax (630) 783-2590

22311 Hufsmith-Kohrville Rd. Tomball, TX 77375
ph (281) 351-0274 Fax (281) 351-1514





4. Position eyebolt and angle bracket as shown in figure 4 and weld the angle bracket to the cover.
5. Secure eyebolt to angle bracket with 1/2" top lock nut with indented flat side facing away from the eyebolt. Make sure to apply a small amount of lube (grease, machine oil, etc.) onto Eyebolt threading prior to top lock nut application.

Fig. 4

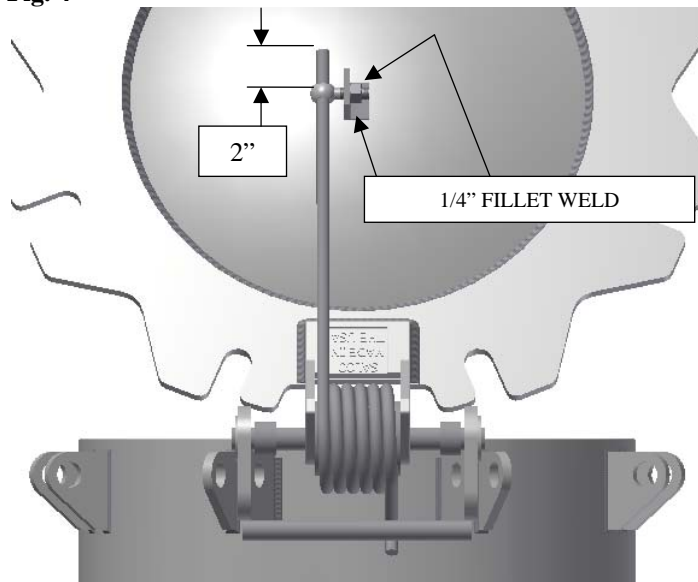

1385 101st St., Suite A Lemont, IL 60439
ph (630) 783-2570 Fax (630) 783-2590

22311 Hufsmith-Kohrville Rd. Tomball, TX 77375
ph (281) 351-0274 Fax (281) 351-1514