



INSTALLATION INSTRUCTIONS FOR BOVHKITCSM04B

Upon receiving the Safeguard BOV Operating System kit (BOVHKITCSM04B), inspect to make sure it has not been damaged in shipment and that all items listed in the parts list are present and accounted for.

1. Make sure the bottom outlet valve is in closed position.
2. Secure the Locking Bracket to the bottom outlet valve with two 3/4"-10 X 4 5/8" studs and 3/4"-10 lock nuts.
3. Insert the Spring inside the BOV Adapter and secure everything to bottom outlet valve stem with a Hex Bolt 7/16-20 X 2 1/2" (see Fig.2).

NOTE: Make sure the BOV threaded stem hole is free of any debris. Apply a small amount of Loctite to Hex Bolt 7/16-20 X 2 1/2" threading prior to BOV stem hole application.

4. When bottom outlet valve is in closed position the Locking Bracket should be centered and engaged with the BOV Adapter (see Fig. 3 & 4).

Fig. 1

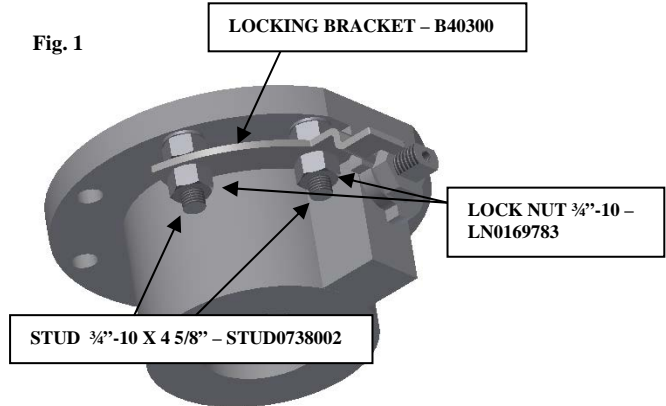

Fig. 2

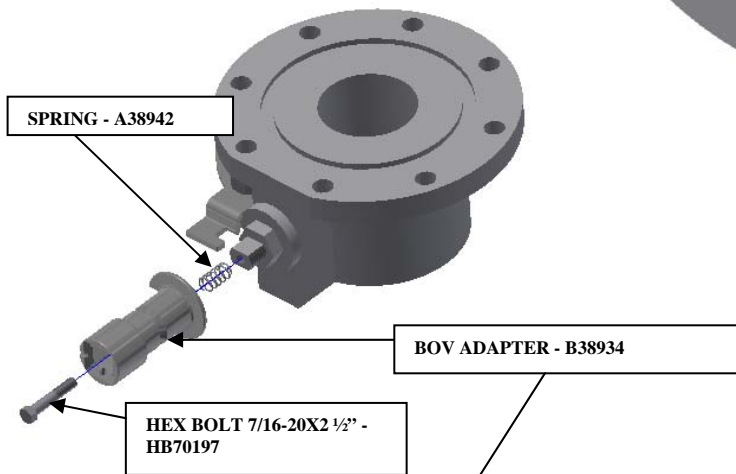

Fig. 3

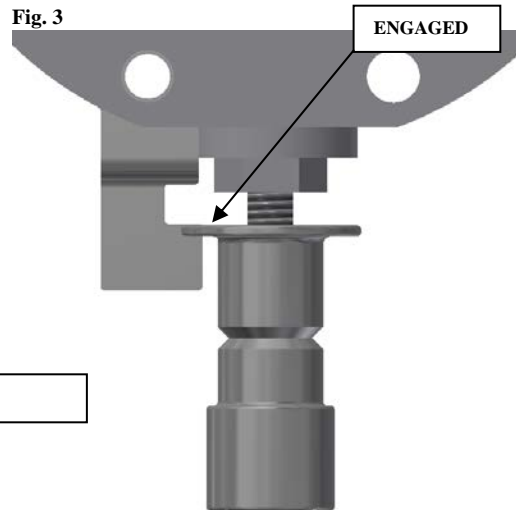
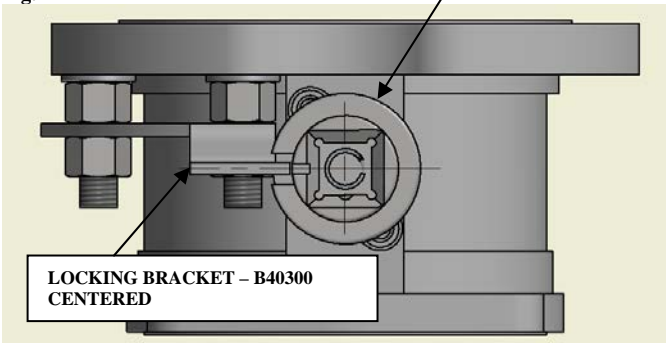
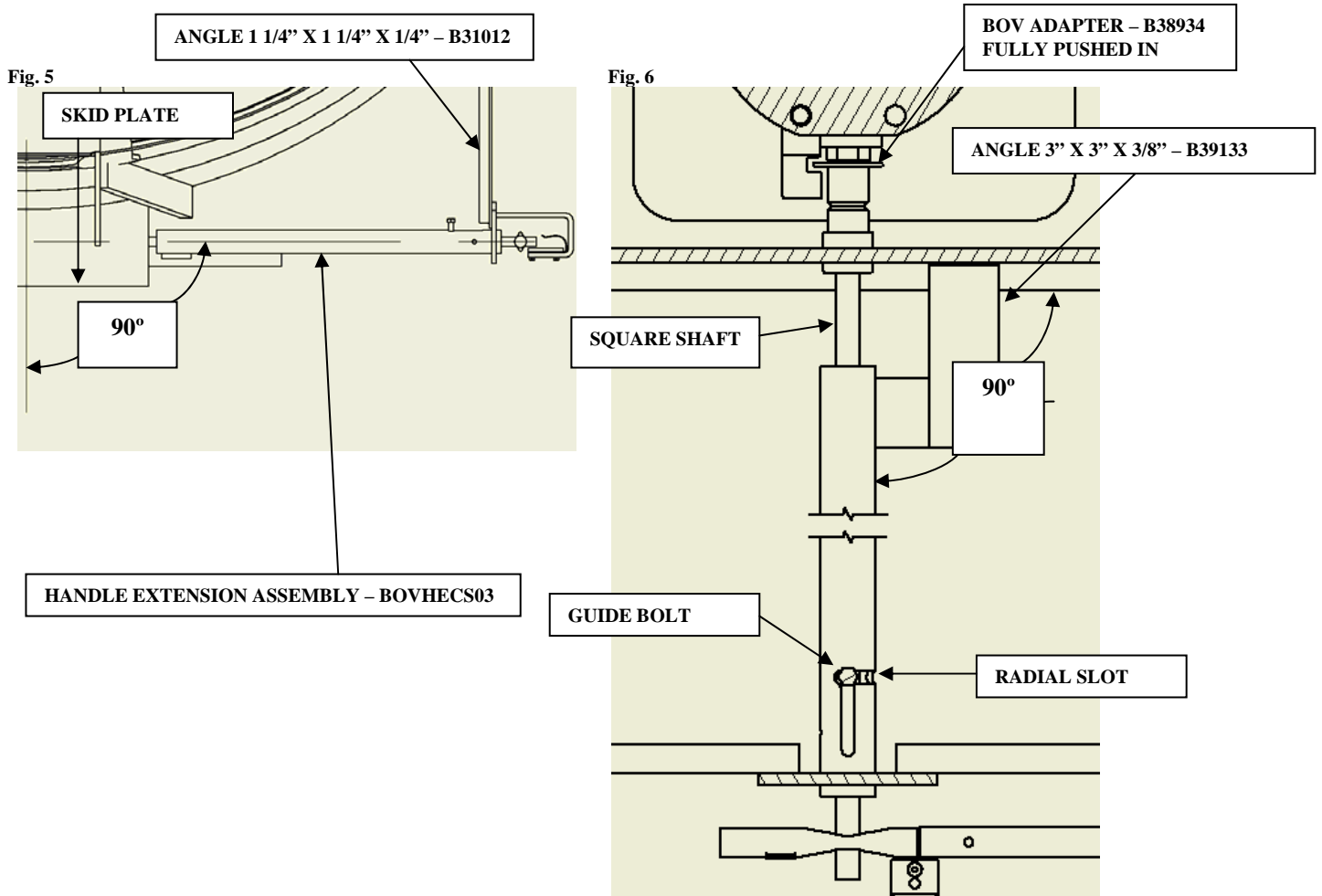

Fig. 4



5. Using a lift table or other type of adjustable lift support, position the Handle Extension Assembly so the square shaft is centered and in line with the BOV stem and the BOV Adapter. Remove safety pins and fully engage and push in the BOV Adapter with the square shaft and make sure the guide bolt is in line with the radial slot (see Fig. 5 & 6).
CAUTION: The Spring inside the adapter might push the BOV Adapter back so a constant pressure will have to be maintained.
6. Tack weld the Angle 3" x 3" x 3/8" to side of the skid plate.
7. Tack weld the Handle Extension Assembly to Angle 3" x 3" x 3/8" (see dwg BOVHKITCSM04B).
8. Tack weld the two Angle Irons 1 1/4" x 1 1/4" x 1/4" to Handle Extension Assembly and to tank or jacket pads (see dwg BOVHKITCSM04B).
9. Cycle the Safeguard BOV Operating System BOVHKITCSM04B few times to make sure everything works properly.
The shaft's linear alignment with the BOV stem should be within +/-1/16" in either vertical or horizontal direction. This can also be verified with the Salco Go-No-Go gauge. Contact Salco Products for more information.
10. Apply full size welds to all connection points (see dwg BOVHKITCSM04B).

NOTE: All tack and full size welds are to be done per installer's weld procedure.









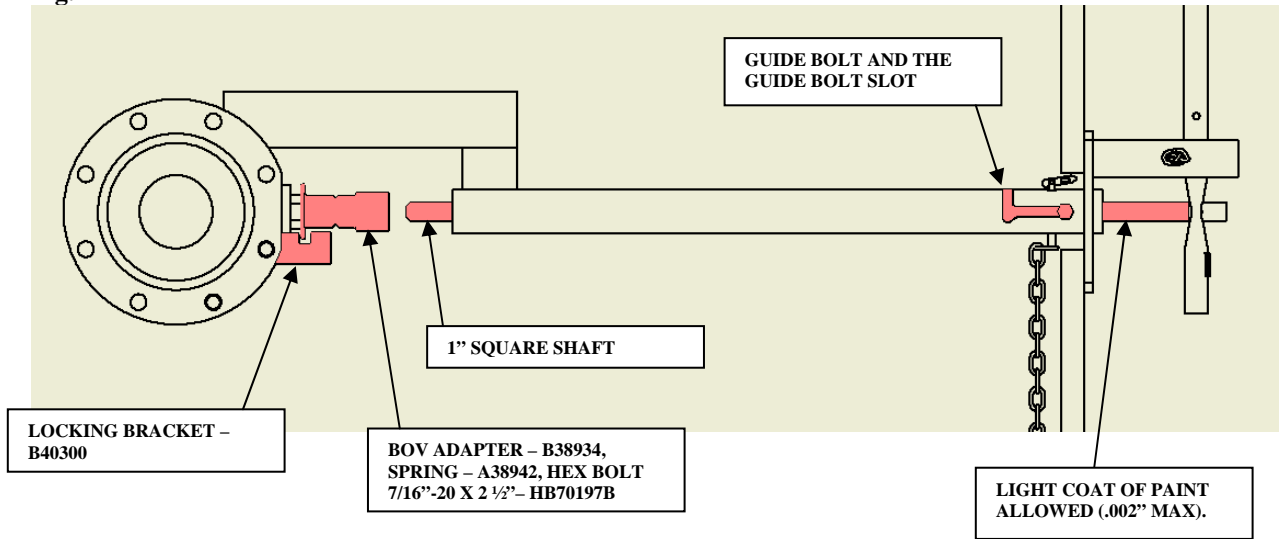

NOTE: Customer to cut ANGLE 1 1/4" X 1 1/4" X 1/4" and ANGLE 3" X 3" X 3/8" upon application to the car if required.

11. Unless otherwise noted, all components and areas highlighted in Fig. 7 must **NOT** be painted and should be mask taped.

Fig. 7

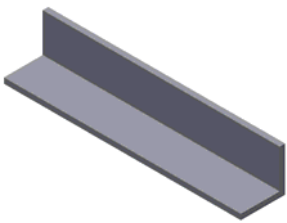

PARTS LIST:

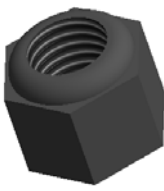
1-HANDLE EXTENSION ASSY. (BOVHECS03) 	1 – BOV ADAPTER (B38934) 	1 – SPRING (A38942) 
1 – HEX BOLT 7/16"-20 X 2 1/2" (HB70197) 	1 – ANGLE 3" X 3" X 3/8" (B39133) 	2 – ANGLE 1 1/4" X 1 1/4" X 1/4" (B31012) 
1 – LOCKING BRACKET (B40300) 	1 – BOV DECAL (DBOV2224V01) (NOT SHOWN)	2 – STUD 3/4"-10X4 5/8" (STUD0738002) 
2-LOCK NUT 3/4"-10 UNC (LN0169783) 		

TOOLS REQUIRED:

- 4" - 6" c-clamp (3 pcs.) or 4" - 6" locking c-clamp (3 pcs.).
- Hammer
- Loctite
- Marker
- Small size level and square
- Tape measure
- Ratchet w/ 5/8" deep socket



PDP3.04.2 - Rev 5