



INSTALLATION INSTRUCTIONS FOR BOVHKITCSM02

Upon receiving the Safeguard BOV Operating System kit (BOVHKITCSM02), inspect to make sure it has not been damaged in shipment and that all items listed in the parts list are present and accounted for.

1. Make sure the bottom outlet valve is in the closed position.
2. Secure the Locking Bracket to the bottom outlet valve with either two $\frac{3}{4}$ "-10 threaded studs and $\frac{3}{4}$ "-10 heavy hex nuts, or $\frac{3}{4}$ "-10 bolts (provided by the installer, see Fig. 1).
3. Insert the Spring inside the BOV Adapter and secure everything to bottom outlet valve stem with a Hex Bolt $\frac{7}{16}$ "-20 x $2\frac{1}{2}$ " (see Fig.2).
NOTE: When inserting the Hex Bolt $\frac{7}{16}$ "-20 x $2\frac{1}{2}$ " into the BOV stem hole, make sure to apply a small amount of Loctite onto threading.
4. When the bottom outlet valve is in closed position, the Locking Bracket should be centered and engaged with the BOV Adapter (see Fig. 3 & 4).

Fig. 1

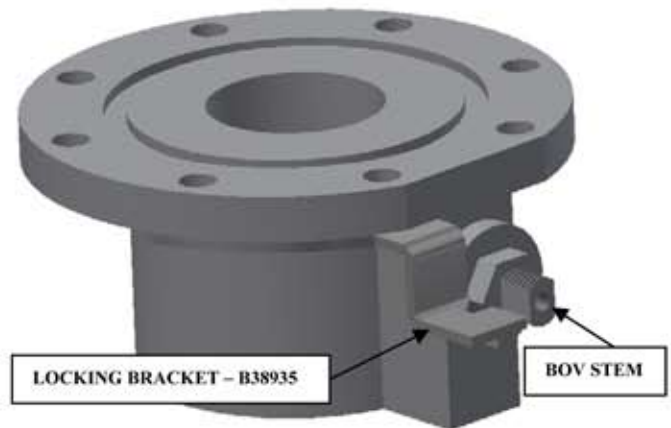

Fig. 2

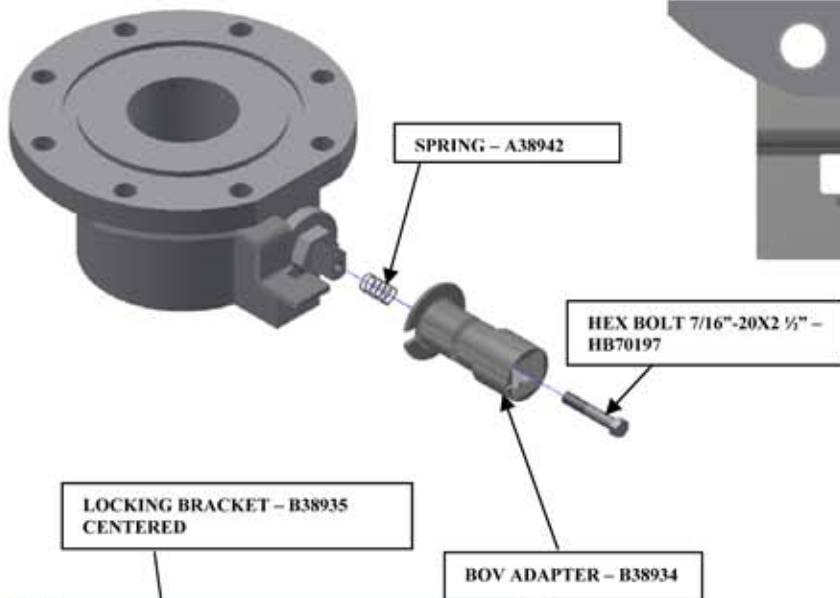

Fig. 3

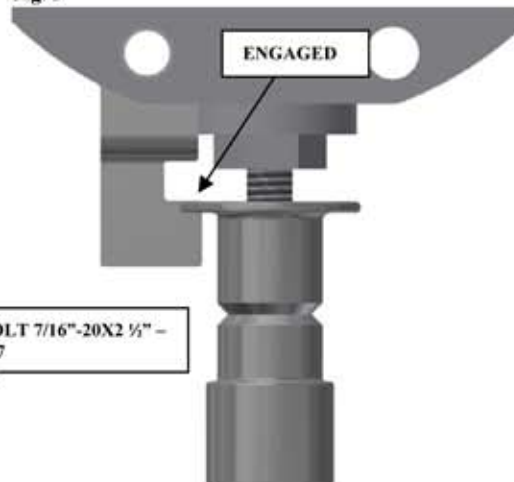
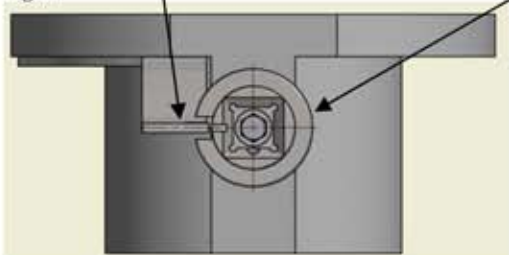
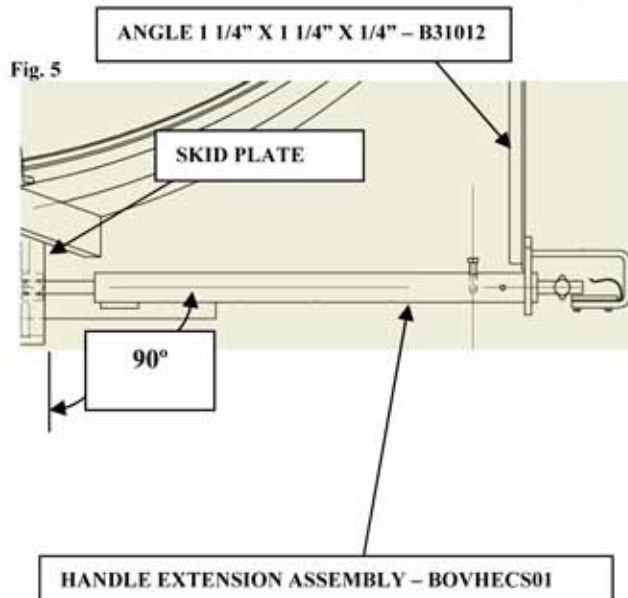

Fig. 4



5. Using a lift table or other type of adjustable lift support, position the Handle Extension Assembly so the square shaft is in line with the BOV Adapter. Remove safety pins and fully engage and push in the BOV Adapter with the square shaft. Make sure the guide bolt is in line with the radial slot (see Fig. 5 & 6).
CAUTION: The Spring inside the adapter might push the BOV Adapter back so a constant pressure will have to be maintained.
6. Tack weld the Angle 3" x 3" x 3/8" to the side of the skid plate.
7. Tack weld the Handle Extension Assembly to Angle 3" x 3" x 3/8" (see dwg BOVHKITCSM02).
8. Tack weld the two Angle Irons 1 1/4" x 1 1/4" x 1/4" to Handle Extension Assembly and to the tank or jacket pads (see dwg BOVHKITCSM02).
9. Cycle the Safeguard BOV Operating System BOVHKITCSM02 a few times to make sure everything works properly. **The shaft's linear alignment with the BOV stem should be within +/-1/16" in either the vertical or horizontal direction. This can also be verified with the Salco Go-No-Go gauge. Contact Salco Products for more information.**
10. Apply full size welds to all connection points (see dwg BOVHKITCSM02).

NOTE: All tack and full size welds are to be done per installer's weld procedure.



NOTE: Customer to cut ANGLE 1 1/4" X 1 1/4" X 1/4" and ANGLE 3" X 3" X 3/8" upon application to the car if required.

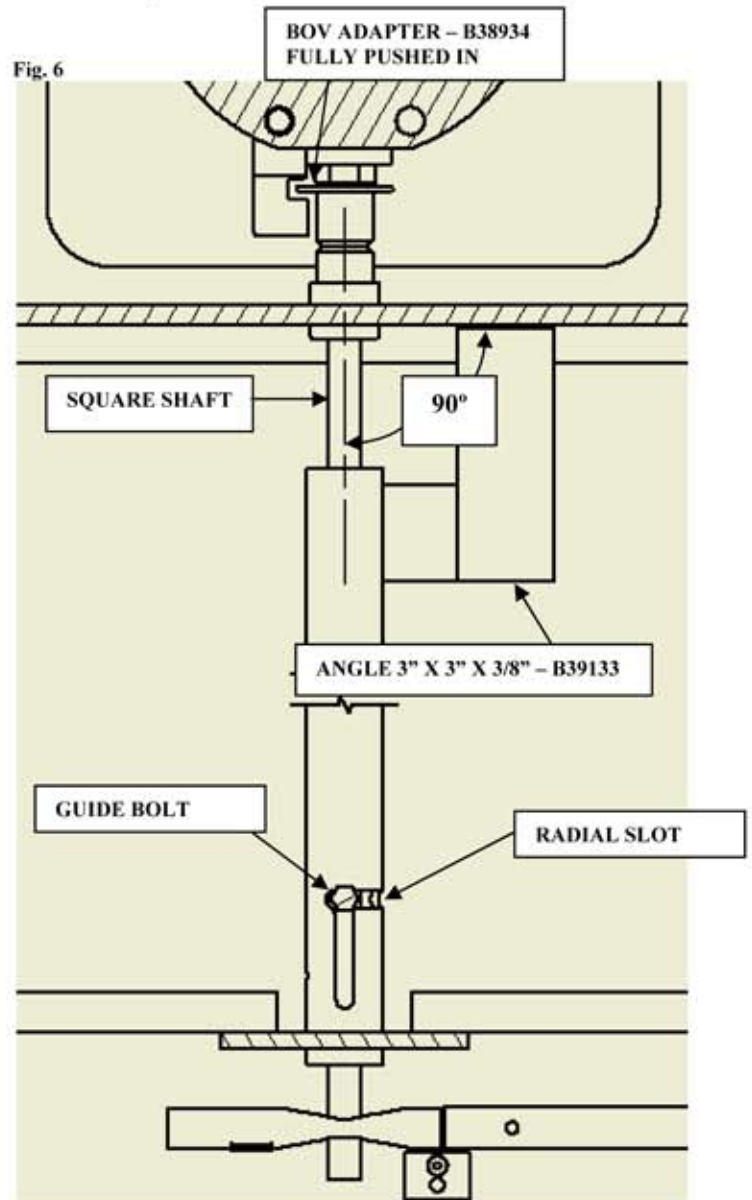

11. Unless otherwise noted, all components and areas highlighted in Fig. 7 must not be painted and should be masked taped.
Fig. 7

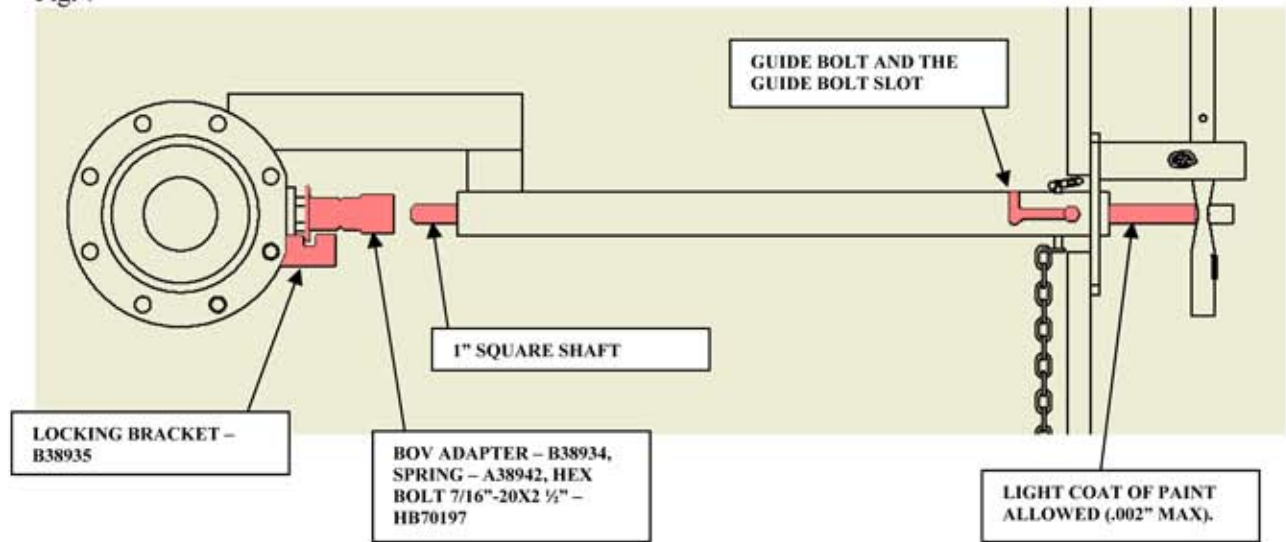

PARTS LIST:

1-HANDLE EXTENSION ASSY. (BOVHECS01)	1 – BOV ADAPTER (B38934)	1 – SPRING (A38942)
1 – HEX BOLT 7/16"-20 X 2 1/2" – (HB70197)	1 – ANGLE 3" X 3" X 3/8" (B39133)	2 – ANGLE 1 1/4" X 1 1/4" X 1/4" (B31012)
1 – LOCKING BRACKET (B38935)	1 – BOV DECAL (DBOV2224V01)	
	(NOT SHOWN)	

TOOLS REQUIRED:

- 4" - 6" c-clamp (3 pcs.) or 4" - 6" locking c-clamp (3 pcs.).
- 16" or larger size channellock pliers.
- Hammer.
- 5/16" punch.
- Marker.
- Small size level and square.
- Tape measure.