



INSTALLATION INSTRUCTIONS FOR BOVHKITCSARI02

Upon receiving the Safeguard BOV Operating System kit (BOVHKITCSARI02) inspect to make sure it has not been damaged in shipment and that all items listed in the parts list are present and accounted for.

1. Make sure the bottom outlet valve is in closed position.
2. Determine which Spacer (Spacer 3/8" A40086 or Spacer 1/2" A39824) to use so the Locking Bracket is centered with the bottom outlet valve stem (see Fig. 1).
3. Secure the Locking Bracket to the bottom outlet valve with either two 3/4"-10 threaded studs and 3/4"-10 heavy hex nuts or 3/4"-10 bolts (provided by the installer).
4. Insert the Spring inside the BOV Adapter and secure everything to bottom outlet valve stem with a Spring Pin (see Fig.2).

NOTE: When inserting the spring pin into the BOV stem hole either gently tap the spring pin in with a stem braced on the opposite side or use a pair of C-channel pliers.

5. When bottom outlet valve is in closed position the Locking Bracket should be centered and engaged with the BOV Adapter (see Fig. 3 & 4).

Fig. 1

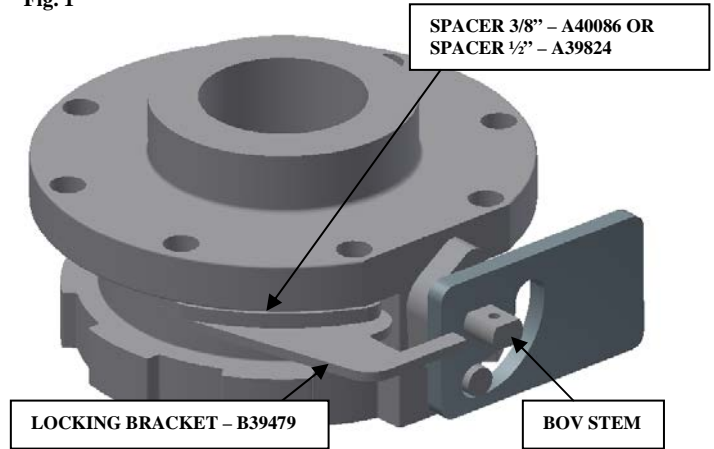

Fig. 2

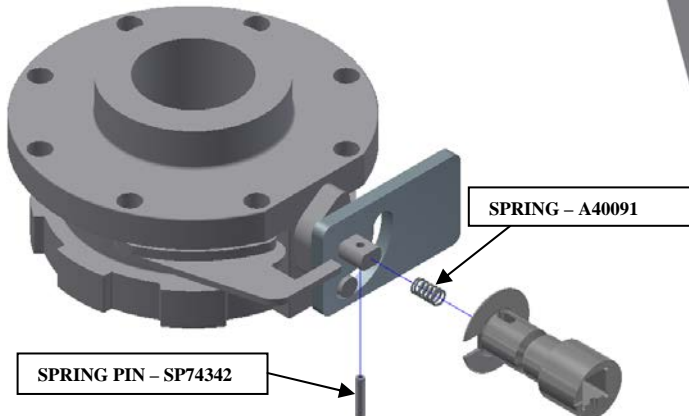

Fig. 3

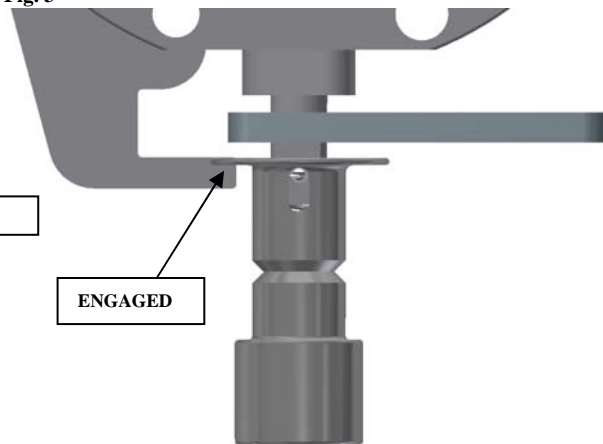
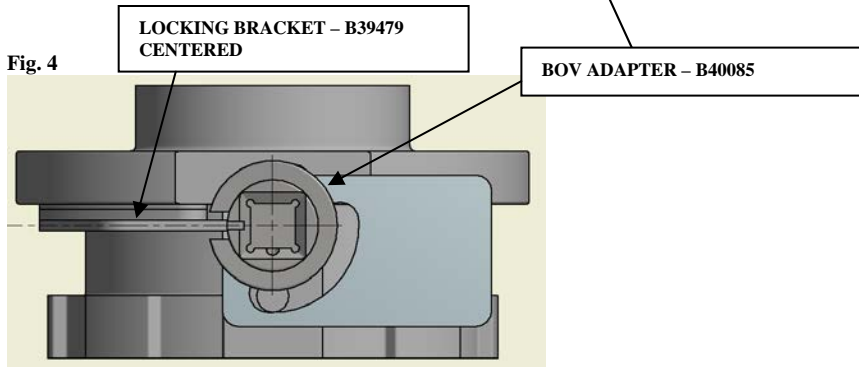
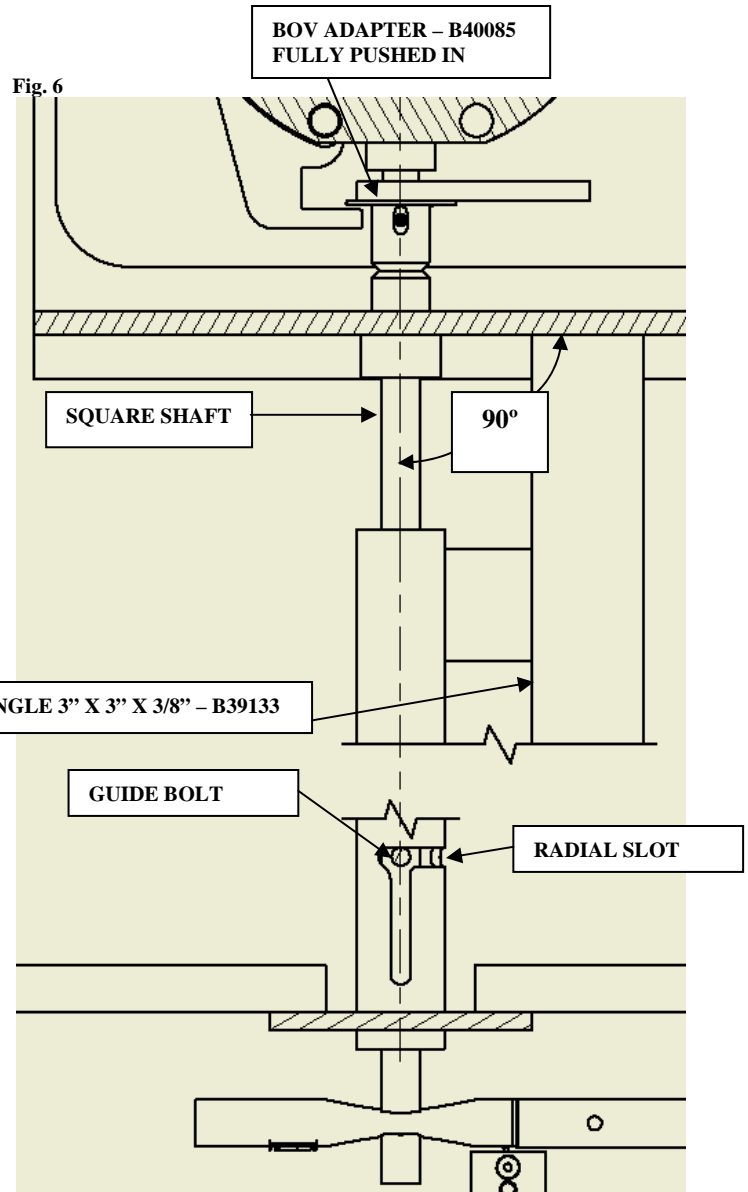
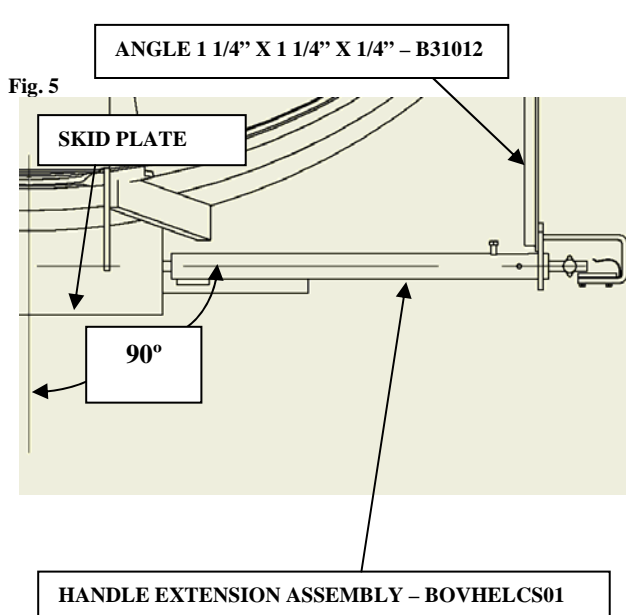

Fig. 4



6. Using a lift table or other type of adjustable lift support, position the Handle Extension Assembly so the square shaft is centered and in line with the BOV stem and the BOV Adapter. Remove safety pins and fully engage and push in the BOV Adapter with the square shaft and make sure the guide bolt is in line with the radial slot (see Fig. 5 & 6).
CAUTION: The Spring inside the adapter might push the BOV Adapter back so a constant pressure will have to be maintained.
7. Tack weld the Angle 3" x 3" x 3/8" to side of the skid plate.
8. Tack weld the Handle Extension Assembly to Angle 3" x 3" x 3/8" (see dwg BOVHKITCSARI02).
9. Tack weld the two Angle Irons 1 1/4" x 1 1/4" x 1/4" to Handle Extension Assembly and to tank or jacket pads (see dwg BOVHKITCSARI02).
10. Cycle the Safeguard BOV Operating System BOVHKITCSARI02 few times to make sure everything works properly.
11. Apply full size welds to all connection points (see dwg BOVHKITCSARI02).

NOTE: All tack and full size welds are to be done per installer's weld procedure.



NOTE: Customer to cut ANGLE 1 1/4" X 1 1/4" X 1/4" and ANGLE 3" X 3" X 3/8" upon application to the car if required.

PARTS LIST:

1-HANDLE EXTENSION ASSY. (BOVHECS01)	1 – BOV ADAPTER (B40085)	1 – SPRING (A40091)
1 – SPRING PIN (SP74342)	1 – ANGLE 3" X 3" X 3/8" (B39133)	2 – ANGLE 1 1/4" X 1 1/4" X 1/4" (B31012)
1 – LOCKING BRACKET (B39479)	1-SPACER 3/8" (A40086)	1 – SPACER 1/2" (A39824)
1 – BOV VELCRO COVER (C39211) (NOT SHOWN)	1 – BOV DECAL (DBOV2224V01) (NOT SHOWN)	
<p>NOTE: To be applied over the guide bolt slot only during the paint prep work such as sand blasting or sanding. Intention is to prevent lose shavings from entering inside.</p>		