

UHMWPE Lined Hammer Union



TANK TRAILER

UHMWPE Lined Hammer Union
Part Number: HSHU4FXF206

Designed for corrosive liquid transfer, the UHMWPE-Lined Hammer Union features a durable ductile iron body and corrosion-resistant liner for long-lasting, reliable performance across demanding applications.

FEATURES & BENEFITS

- Designed for corrosive applications.
- Body constructed of durable Ductile Iron.
- Lined with corrosion resistant UHMWPE.
- Available in a variety of sizes.
- Superior sealing surface.
- Available in both flanged male and female fittings.
- Figure 206.

THE PROBLEM

Although known for their quick connecting capabilities, many current hammer union fittings struggle to withstand the harsh commodities they are transferring.

OUR SOLUTION

Stucki's UHMWPE Lined hammer union offers both corrosion and abrasion resistance on all wetted surfaces. A fitting designed to reduce maintenance and labor costs associated with replacing lesser disposable alternatives.

See back side for technical specs ►

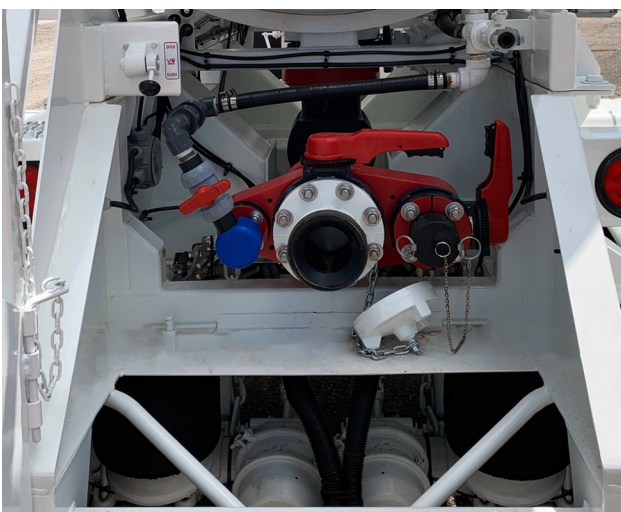

Technical Specifications

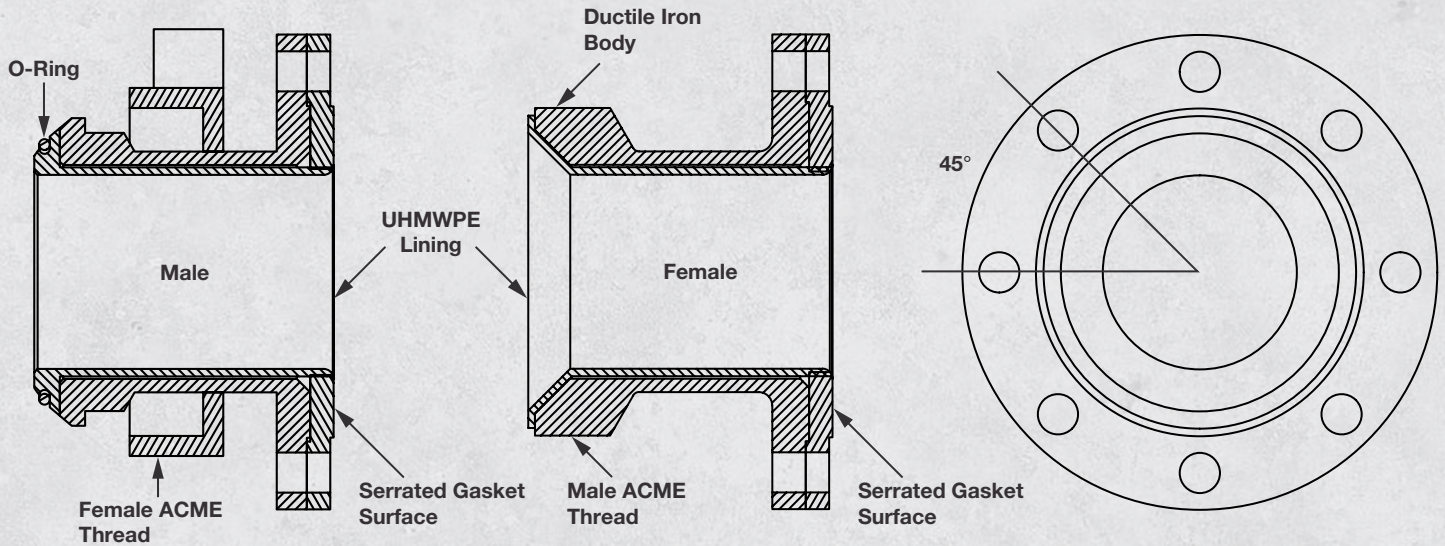

Mechanical Properties

Pressure Rating	400 psi
Temperature Rating	-20°F to +150°F
Body Material	Ductile Iron
Liner Material	UHMWPE
Weight	26 lbs
Gasket Materials	EPDM, Viton
Sizes Available	4in, 6in

Wear Properties

In the test, each material was weighed before and after being rotated at 1,750rpm in a sand-and-water mixture for seven hours (known as a sand slurry abrasion test). The numbers in the graph represent relative weight loss - lower numbers mean higher resistance to abrasion.

Sand Slurry Abrasion Test Results

