

NO.	PART NAME	PART#	RE	MATERIAL
1	VENTED HATCH COVER 30"	VPHC3007AS	1	SEE DWG
2	FLAT WASHER 5/16" USS	WASH516SS	2	18-8 SS
3	HEX BOLT 5/16"-18X1 1/2"	HB51615SS	2	18-8 SS
4	HATCH COVER ARM ASSEMBLY 30"	AE3007PREA	1	SEE DWG

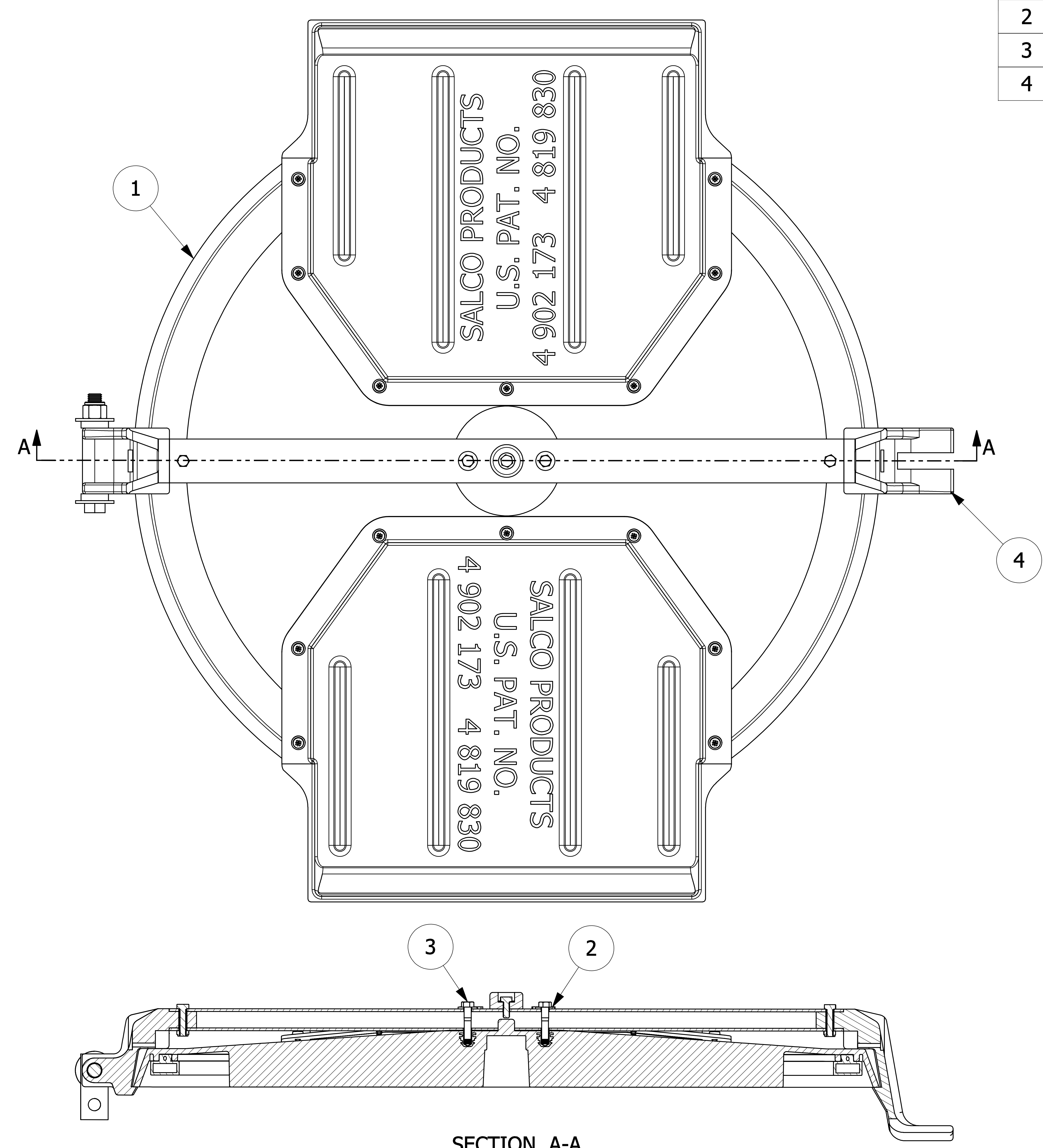

SECTION A-A

B	BRG	7-22-09	UPDATED DRAWING WITH NEW PHC3007AS
A	PJG	3-19-08	NEW PART ADDED TO SYSTEM
REV	BY	DATE	DESCRIPTION

UNLESS OTHERWISE SPECIFIED DIMENSIONAL TOLERANCES	DRAWN BY:	BRG
FRACTIONAL: ±1/16	CHECKED BY:	PJG
X.XX: ±.03	PROTOTYPE BY:	BRG
X.XXX: ±.015	PROTOTYPE DATE:	11/28/2007
ANGULAR: ±1°	APPROVED FOR PRODUCTION BY:	PJG
THIRD ANGLE PROJECTION	PRODUCTION DATE:	3/19/2008

SALCO PRODUCTS, INC.

VENTED HATCH COVER 30"

SEE BOM

PROJECT #: **060314** SHEET #: **1 OF 1** SCALE: **1/2**

DRAWING #: **E24509** PART #: **VPHC3007PRE**

THIS PRINT, PROPERTY OF SALCO PRODUCTS INC. CONTAINS PROPRIETARY INFORMATION AND MUST NOT BE COPIED, REPRODUCED, OR USED DETRIMENTALLY TO OUR INTEREST.