



A. STUCKI

INDUSTRIAL COMPANY

GIVING YOUR SCRAP RAILCAR PARTS

NEW LIFE

www.stucki.com



COUPLERS, YOKES & WHEELS

NEW & RECONDITIONED

RAILCAR COUPLERS

TYPE	MODEL
Freight	EF511
Freight	EF525
Freight	EF528
Freight	SBE60
Freight	SBE67
Freight	SBE68
Freight	SBE69
Freight	F70
Freight	SF70
Freight	SE60
Rotary	FR205
Rotary	FR207
Rotary	FR209
Rotary	FR304

LOCOMOTIVE COUPLERS

TYPE	MODEL
Loco	E8311
Loco	E8301
Loco	E8306
Loco	BE108
Loco	E4936
Loco	E8316
Loco	SBE108
Loco	SBE4936
Loco	E7327
Loco	E4881
Loco	BE110
Loco	F8513
Loco	F8306
Loco	F8301
Loco	BF10

RAILCAR YOKES

TYPE	MODEL
Freight	Y40
Freight	SY40
Freight	Y45
Freight	SY294
Rotary	3748
Rotary	52172-1
Rotary	50631-1

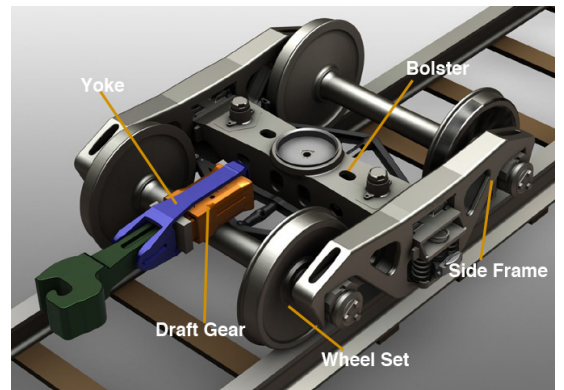

COUPLERS & YOKES



EXAMPLE OF PRODUCT MARKINGS

Bolster Markings



Side Frame Markings



WHEELS SETS

MODEL	WEIGHT
-------	--------

100 TON 6½" x 12" 2600 lbs

Actual weight may vary +-5%



FREIGHT CAR DRAFT GEARS

INDEPENDENT

■■■■■■■■■■ DRAFT GEAR

A Division of A.Stucki Company

NEW & RECONDITIONED



Independent Draft Gear
PowRGuard™ XE & GX



Miner
Crown SE



Cardwell Westinghouse
Mark 50 & R500



Miner
TF 800

LOCOMOTIVE DRAFT GEARS RECONDITIONED



Keystone
NC391



Keystone
NC390

DRAFT GEARS

MODEL	WEIGHT
Mark 50	386 lbs
Mark R500	375 lbs
Crown SE	390 lbs
TF 880	295 lbs
PowRGuard™	367 lbs
NC390	1250 lbs
NC391	1250 lbs

Actual weight may vary +/-5%



LARGEST RECONDITIONER IN THE U.S.

Independent Draft Gear leads the nation in distributing, manufacturing, and reconditioning locomotive and freight car draft gears.



GET YOUR PARTS FAST

Using North America based vendors allows for quick 3 – 5 day turnaround times vs. the 30 day industry standard.

PROGRAM WORK

In stock draft gears can help jumpstart your changeout programs. Continuous core exchange and reconditioning will keep your project moving without delay.

LET'S FIND A SOLUTION TOGETHER.
CONTACT US TODAY.



A.STUCKI
.....COMPANY

sales@stucki.com

412.424.0560

www.stucki.com