



**Benefits**

- Extends Life of Brake Shoes, Wear Liners & Wheels
- EasyKey™ System for easy Key removal, reduces shoe replacement & train inspection efforts, stress & time!
- StopTab-SureHome assures proper support of Shoes & Keys
- Resistant to Fatigue and Vibration
- Effective traceability
- Immediate delivery!

**Features**

- Light weight, reduces injuries & fatigue
- Diagonally corrected
- Provides largest clearance to brake rigging & slack systems
- Brake Heads provide angle correction and EasyKey™ system
- Brake Heads are replaceable in the field using RC-kit
- Available capacities: 18,000 and 24,000 pounds
- Strongest beam available
- Exceeds Quality & Mechanical AAR Standards

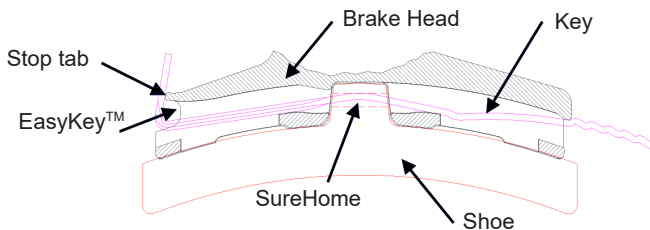
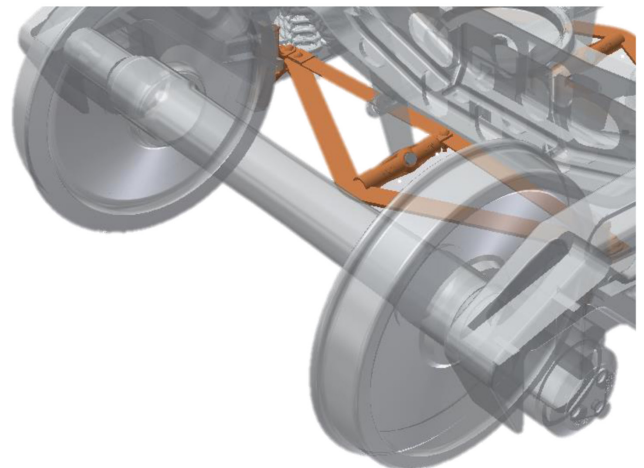
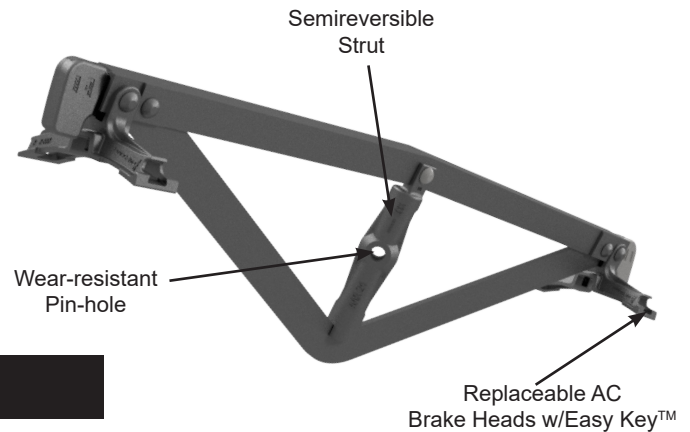

**Easy Key™ System:**

Innovative concept facilitates key removal at each change of Brake Shoes quickly and safely! Stop tab ensures optimal HomeKey position.

**System without interferences:**

Brake rigging-friendly design, provides maximum clearance for levers, bottom rods, bolsters, and axles.



**SELECTION CHART**

| Product Description                            | Side  | Capacity (Pounds) | Pin Hole Diam. | Certificate |
|--|-------|-------------------|----------------|-------------|
| RCL Brake Beam<br>(Patent No. US 8,889,388 B2) | Left  | 18000             | 1 1/8"         | 225         |
|  |       | 24000             | 1 3/8"         | 224         |
|  | Right | 18000             | 1 1/8"         | 225         |
|  |       | 24000             | 1 3/8"         | 224         |

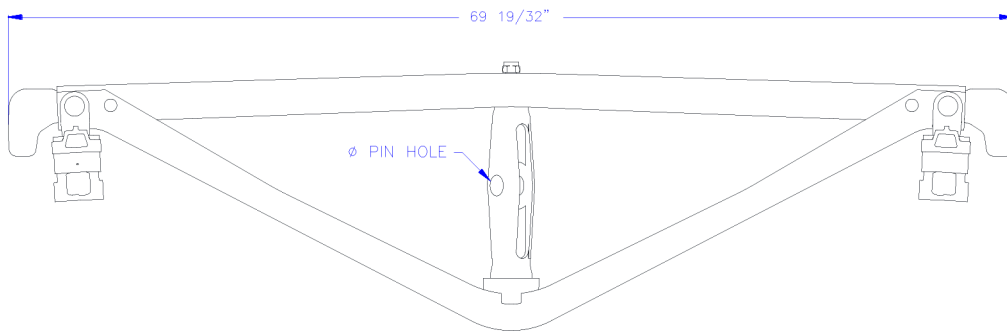

**General Dimensions**

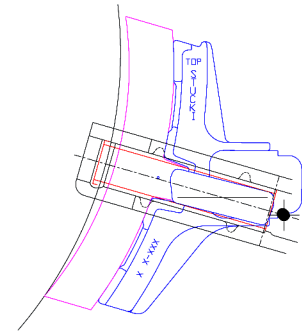

**Location on Truck**

